

Submersible dirty water pump made of stainless steel AISI 304, double mechanical seals ensure long life and reliability. Suitable for dirty water systems with some solids. Applications include wastewater treatment plants and final effluent pumping, irrigation, and water displays. Options include with - without float switch. Solids handling up to 35 mm.



### SPECIFICATIONS

- Maximum liquid temperature: 50°C
- Maximum immersion: 10 m
- Maximum passage of solids: 35 mm

### MATERIALS

- Pump casing, impeller, cover, casing cover and motor casing in AISI 304
- Shaft in AISI 303
- Double mechanical seal with interposed oil chamber: upper in carbon/ceramic/NBR, lower in SiC/SiC/NBR

### TECHNICAL DATA

- Asincronous 2 poles motor
- Insulation class F
- Protection degree IP68
- 1~230V ± 10%, 50Hz - 3~400V ± 10%, 50Hz
- Permanent split capacitor and automatic thermal overload protection for single-phase version
- Thermal protection to be provided by the user for three-phase version
- DNM 1<sup>1/2</sup>

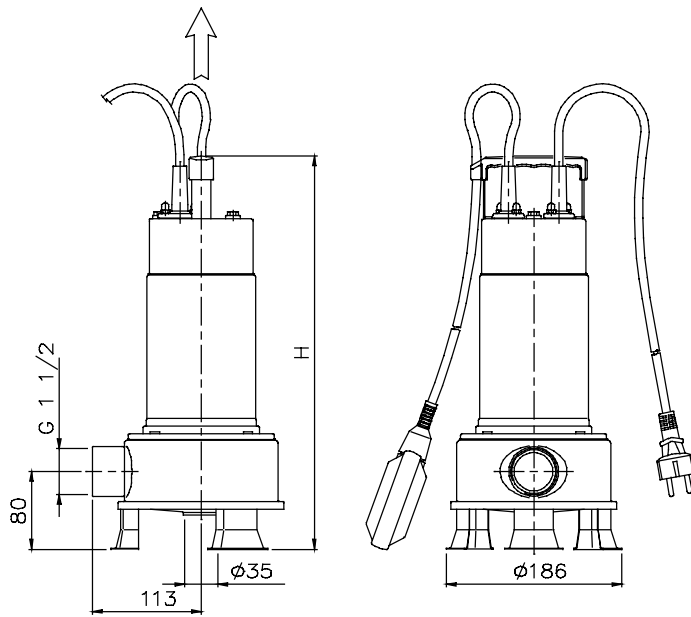

### DIMENSIONAL TABLE

Pump type	(mm)		Weight kg
	H	H2	
RIGHT 75	405	480	10
RIGHT 100	430	500	11,5

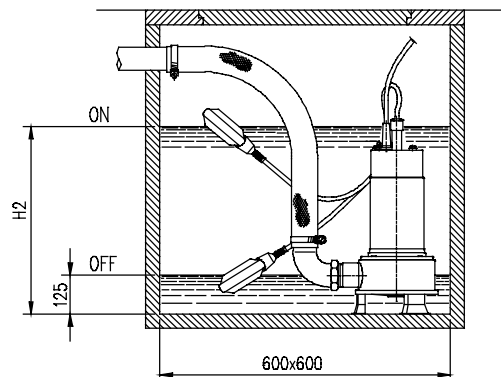

## PERFORMANCE CURVES (according to ISO 9906 Annex A)

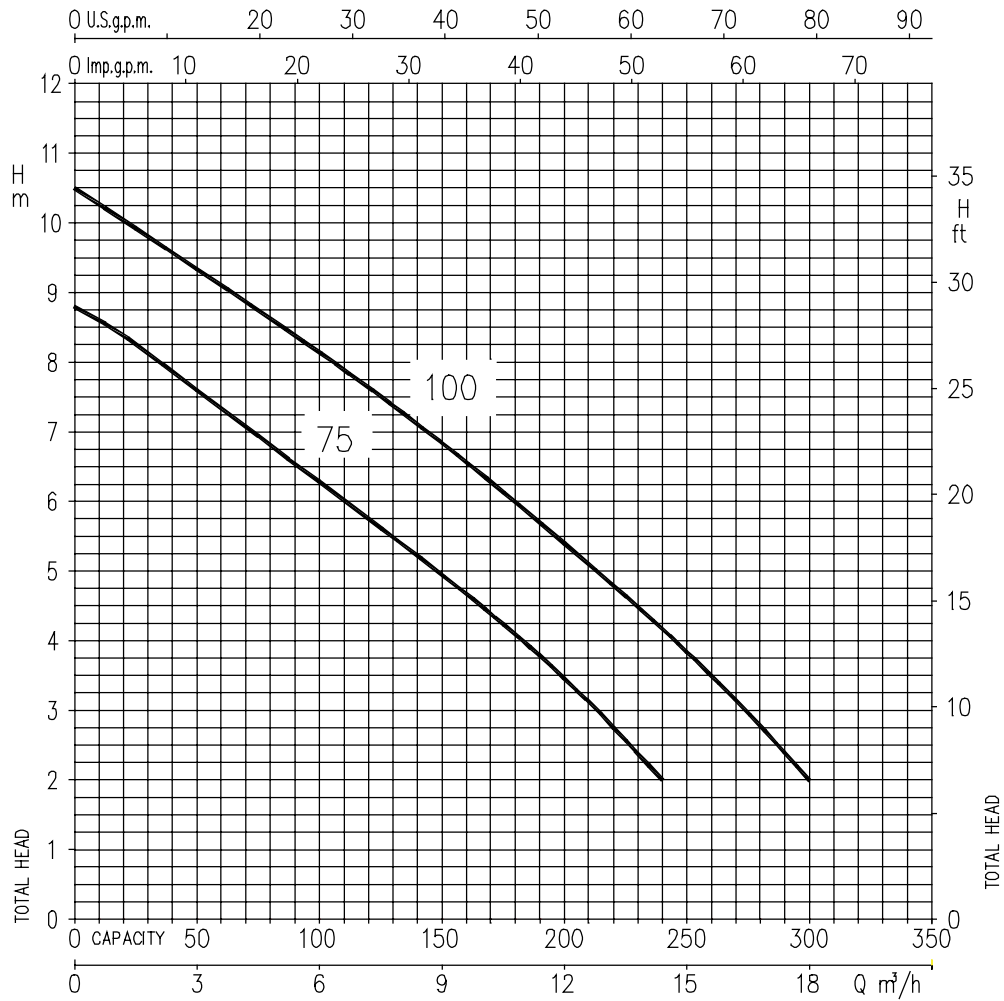

### PERFORMANCE TABLE

Pump type		kW	Capacitor		Absorbed Current(A)		Q=Capacity								
Single-phase 230V 50Hz	Three-phase 400V 50Hz		μF	V <sub>c</sub>	1~	3~	l/min m³/h	40	80	100	120	160	200	240	300
								H=Total head							
RIGHT 75 M	RIGHT 75	0,55	20	450	4,8	2,1	7,8	6,8	6,2	5,7	4,7	3,4	2	-	-
RIGHT 100 M	RIGHT 100	0,75	31,5	450	5,7	2,6	9,5	8,6	8,1	7,6	6,6	5,4	4,2	2	2